

Delta Element Steam Traps

Models

3A

GM3

CRN: Canadian Registration Number Available

FOR PROCESS AND HEATING SYSTEMS

A series of steam traps designed for fast start-up and modulating discharge with no live steam loss on service up to 30 psig differential. Ideal where a forged body with "Y" type strainer is required to handle light condensate loads including low pressure driplegs.

- **Maximum operating differential pressure:** 30 psig / 2,1 bar
- **Single blade element** – offers long-term, trouble-free service because it's not prone to dirt build-up as encountered with many other bimetal designs
- **Stainless Steel internals** – leads to longer service life since materials are highly resistant to fatigue and corrosion
- **Modulating discharge** – automatically adjusts to operating pressure and load, overcoming problems associated with cyclic discharge
- **Integral strainer and check valve** – strainer protects trap from dirt while check valve prevents backflow during shutdown
- **Continuous air and CO2 venting** – maximizes heat transfer while minimizing corrosion
- **Easy maintenance** – traps are in-line repairable when isolated from live steam system and can be up and running again in minutes

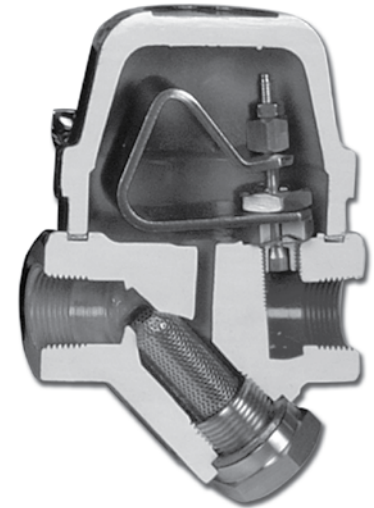

ORDERING SCHEMATIC

MODEL				6	7	8	
M	0	0	3	A	1	1	0

MODEL				6	7	8	
G	M	0	0	3	4	1	0

6	SIZE
1	3/8" (3A)
2	1/2" (All)
3	3/4" (All)
4	1" (GM3)
5	1-1/4" (GM3)
6	1-1/2" (GM3)

7	CONNECTIONS
1	NPT
2	FSW
3	150# Flange
8	BSPT
9	BSPP

8	SPECIALS
0	None
1	DTC
3	Integral Blowdown



A Division of
Richards Industries
3170 Wasson Road
Cincinnati, OH 45209

toll free. 800.543.7311
local. 513.533.5600
fax. 513.871.0105

steam@richardsind.com
www.bestobellsteamtraps.com

FOR PROCESS AND HEATING SYSTEMS
SPECIFICATIONS

Maximum Differential Pressure: 30 PSIG (2,1 bar)

Maximum Operating Pressure: 750 PSIG (52 bar)

Maximum Body Temperature: 650°F (343°C)

MATERIALS

Body & Cover: Forged Carbon Steel A105

Valve Seat: 303 SST & Cone: 17-4 SST

Bi-Metal: Stainless Steel NiCr

Strainer: Stainless Steel 304

Bolts: Steel GR8

Gasket: Flexible Graphite

Options: Double Threaded Strainer Cap (DTC) for blowdown valve attachment; selection of integral blowdown valves

Mounting: From horizontal to vertical (see Installation & Maintenance Instructions). Self-Draining and freeze-resistant when mounted in vertical position.

Line Sizes:

Model 3A: 3/8", 1/2", 3/4"

Model GM3: 1/2", 3/4", 1", 1-1/4", 1-1/2"

End Connections: Threaded NPT, BSPT, BSPP, SW, Raised Face Flanges (ANSI 150, DIN, BS, JIS)

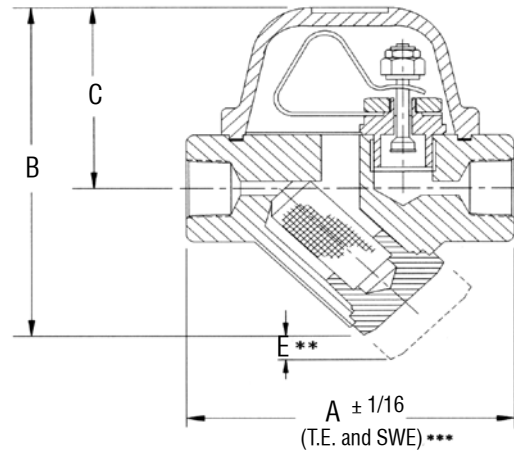

Model GM3						
1/2"-3/4"	A	B	C	D	E	Wt
inches	4	6	3.625	4	2.625	8.4 lbs
mm	102	152	92	102	67	3.8 kgs
1"	A	B	C	D	E	Wt
inches	5	6.75	3.625	4	3.50	9.9 lbs
mm	127	171	92	102	89	4.5 kgs
1-1/4", 1-1/2"	A	B	C	D	E	Wt
inches	7.125	9.50	5.875	6	4.375	33 lbs
mm	181	241	149	102	67	15 kgs
Model 3A						
3/8", 1/2", 3/4"	A	B	C	D	E	Wt
inches	4	5	3.25	3.125	2.25	5.5 lbs
mm	102	127	83	79	57	2.5 kgs

Notes: dimension D is overall width; ** dimension E is withdrawal distance for strainer, *** dimensions shown are for threaded or socket weld ends, contact factory for other dimensions

CAPACITY CHARTS: CONDENSATE CAPACITY AT DIFFERENTIAL PRESSURE

Model GM3		For smaller loads, consider Model 3A						
Size	Differential Pressure, psi (bar)	2 (0,14)	5 (0,34)	10 (0,69)	15 (1,03)	20 (1,38)	25 (1,72)	30 (2,07)
1/2"	Cold start-up, lbs/hr	1000	1700	2100	2500	2900	3000	3200
	Hot (Dripleg), lbs/hr	500	700	750	750	750	750	750
3/4"	Cold start-up, Kg/hr	453	771	952	1134	1315	1360	1451
	Hot (Dripleg), Kg/hr	226	317	340	340	340	340	340
1"	Cold start-up, lbs/hr	1800	3200	5100	6800	8000	8900	9000
	Hot (Dripleg), lbs/hr	700	950	1300	1600	1700	1800	2000
	Cold start-up, Kg/hr	816	1451	2313	3129	3628	4037	4082
	Hot (Dripleg), Kg/hr	317	430	589	725	771	816	907
1-1/4"	Cold start-up, lbs/hr	4000	7000	10000	13000	16000	18000	20000
	Hot (Dripleg), lbs/hr	2400	2800	3200	3700	3900	4000	4100
1-1/2"	Cold start-up, Kg/hr	1814	3175	4536	5896	7257	8164	9072
	Hot (Dripleg), Kg/hr	1088	1270	1451	1678	1723	1814	1859
Model 3A		For smaller loads, consider Model DM6						
Size	Differential Pressure, psi (bar)	2 (0,14)	5 (0,34)	10 (0,69)	15 (1,03)	20 (1,38)	25 (1,72)	30 (2,07)
3/8"	Cold start-up, lbs/hr	500	1000	1800	2200	2600	2900	3000
	Hot (Dripleg), lbs/hr	175	200	200	200	200	200	200
1/2"	Cold start-up, Kg/hr	226	453	816	997	1179	1315	1360
	Hot (Dripleg), Kg/hr	79	90	90	90	90	90	90

Note: Flow rates are based on discharge to atmospheric pressure, valid for back pressure up to 20% of inlet pressure. Higher back pressure requires reset of control element to obtain these capacities. Consult factory for details.