

Delta Element Steam Traps

Models
DM10E

CRN: Canadian Registration Number Available

FOR FREEZE PROTECTION DRAINAGE OR ULTRA-SUBCOOLED TRACING

Commonly used as an automatic drain for freeze-proof protection of condensate return systems and manifolds, and on tracer systems where maximum use of BTU's from condensate is desired.

- **Easy maintenance** – traps are in-line repairable when isolated from live steam system and can be up and running again in minutes
- **Single blade element** – offers long-term, trouble-free service because it's not prone to dirt build-up as encountered with many other bimetal designs
- **Stainless Steel internals** – leads to longer service life since materials are highly resistant to fatigue and corrosion
- **Modulating discharge** – automatically adjusts to operating pressure and load, overcoming problems associated with cyclic discharge
- **Continuous air and CO2 venting** – maximizes heat transfer while minimizing corrosion
- **Unique valving operation** – specifically designed to be closed steam-tight above 180°F (82°C)

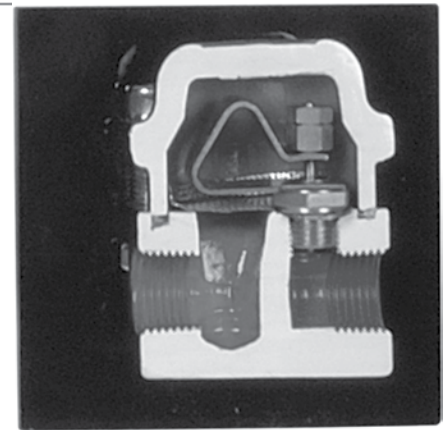

ORDERING SCHEMATIC

MODEL							
D	M	1	0	E	1	1	0

6	SIZE
1	3/8"
2	1/2"
3	3/4"

7	CONNECTIONS
1	NPT
2	FSW
8	BSPT
9	BSPP

8	SPECIALITIES
0	None



A Division of
Richards Industries
3170 Wasson Road
Cincinnati, OH 45209

toll free. 800.543.7311
local. 513.533.5600
fax. 513.871.0105

steam@richardsind.com
www.bestobellsteamtraps.com

FOR FREEZE PROTECTION DRAINAGE OR ULTRA-SUBCOOLING TRACING
SPECIFICATIONS

Maximum Operating Pressure: 120 psig (8,3 bar)

Maximum Body Pressure: 750 PSIG (52 bar)

Maximum Body Temperature: 750°F (399°C)

MATERIALS

Body & Cover: Forged Carbon Steel A105

Valve Seat: 303 SST

Cone: 17-4 SST

Bi-Metal: Stainless Steel NiCr

Strainer: Stainless Steel 304

Bolts: ASTM-A193, B7

Gasket: Flexible Graphite

End Connections: NPT, BSPT, BSPP, SW

Mounting: From horizontal to vertical (see Installation & Maintenance Instructions). Self-Draining and freeze-resistant when mounted in vertical position.

Line Sizes: 3/8", 1/2", 3/4"

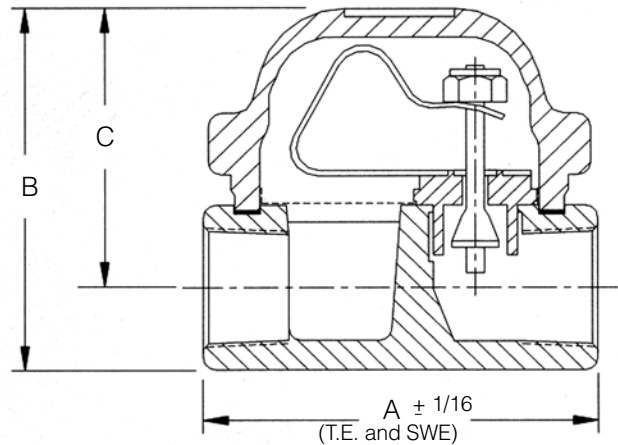
MODEL DM10E SERIES DIMENSIONS

Model DM10E					
3/8", 1/2"	A	B	C	D	Wt
inches	2.438	3.0	2.25	2.438	2.2 lbs
mm	62	76	57	62	1,0 kg
3/4"	A	B	C	D	Wt
inches	4.563	3.125	2.25	2.438	3.0 lbs
mm	116	80	57	62	1,4 kg

BESTOBELL'S DELTA ELEMENT . . . NO LIVE STEAM LOSS

A sophisticated, yet simple, design that will give you years of trouble-free service with absolutely no live steam loss. Bestobell's Delta Element is a triangular shaped bi-metal strip of austenitic and ferritic stainless steels. The materials are rolled together, shaped in the Delta pattern and then heat treated to eliminate stresses. The single blade design provides faster response than found with typical stacked arrangements due to the large surface to mass ratio. The stem is situated at a point that allows the expansion of the bimetal to exert a linear pull on the stem to prevent uneven wear on the sealing surfaces.

Notes: dimension D is overall width; **dimensions shown are for threaded or socket weld ends, contact factory for other dimensions

APPLICATIONS FOR DM10E
Drainage Service

Install at drainage point on manifolds and condensate piping. Trap will remain closed during normal operation of condensate system. If condensate temperature falls below 120° – 180°F (49°C – 82°C), the trap will prevent freeze-ups by opening and providing condensate flow.

CAPACITY CHARTS: CONDENSATE CAPACITY AT OPERATING PRESSURE

Model DM10E		30	40	50	60	70	80	90	100	110	120
Size	Operating Pressure, psi (bar)	(2,1)	(2,8)	(3,5)	(4,1)	(4,8)	(5,5)	(6,6)	(7,6)	(7,6)	(8,3)
3/8"	Hot @ 50°F subcooling, lbs/hr	50	50	50	50	50	50	50	50	50	50
	Hot @ 90°F subcooling, lbs/hr	250	250	250	250	250	250	250	250	250	250
1/2"	Hot @ 10°C subcooling, kgs/hr	22,7	22,7	22,7	22,7	22,7	22,7	22,7	22,7	22,7	22,7
	Hot @ 32°C subcooling, kgs/hr	113	113	113	113	113	113	113	113	113	113

Note: Flow rates are based on discharge to atmospheric pressure, valid for back pressure up to 20% of inlet pressure. Higher back pressure requires reset of control element to obtain these capacities. Consult factory for details.