

# Delta Element Steam Traps

Model  
DM25

CRN: Canadian Registration Number Available

## FOR HIGH PRESSURE PROCESS SERVICES

For use on a steam main dripleg and critical tracing service with differential pressures up to 320 psig (22,1 bar)

- **Easy maintenance** – traps are in-line repairable when isolated from live steam system and can be up and running again in minutes
- **No live steam loss** – for greater energy efficiency and extended seat life, up to 320 psig (22,1 bar)
- **Single blade element** – offers long-term, trouble-free service because it's not prone to dirt build-up as encountered with many other bimetal designs
- **Stainless Steel internals** – leads to longer service life since materials are highly resistant to fatigue and corrosion
- **Modulating discharge** – automatically adjusts to operating pressure and load, overcoming problems associated with cyclic discharge
- **Continuous air and CO<sub>2</sub> venting** – maximizes heat transfer while minimizing corrosion

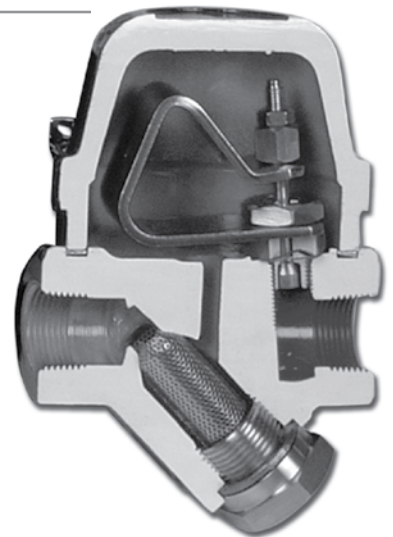

## ORDERING SCHEMATIC

MODEL				6	7	8	
D	M	0	2	5	2	2	0

6	SIZE
2	1/2"
3	3/4"

7	CONNECTIONS
1	NPT
2	FSW
3	150# Flange
4	300# Flange
5	600# Flange
8	BSPT
9	BSPP

8	SPECIALITIES
0	None
1	DTC
3	Integral Blowdown



**BESTOBELLSTEAM**

A Division of  
Richards Industries  
3170 Wasson Road  
Cincinnati, OH 45209

toll free. 800.543.7311  
local. 513.533.5600  
fax. 513.871.0105

steam@richardsind.com  
www.bestobellsteamtraps.com

**FOR STEAM MAIN DRIPLEG AND CRITICAL TRACING**
**SPECIFICATIONS**

Maximum Differential Pressure: 320 psig (22 bar)

Maximum Operating Pressure: 750 psig (52 bar)

Maximum Body Temperature: 750°F (399°C)

**MATERIALS**

Body & Cover: Forged Carbon Steel A105

Valve Seat: 303 SST

Cone: 17-4 SST

Bi-Metal: Stainless Steel NiCr

Strainer: Stainless Steel 304

Bolts: Steel Gr8

Gasket: Flexible Graphite

Options: Double Threaded Strainer Cap (DTC) for blowdown, Double Threaded Strainer Cap (DTC) for blowdown valve attachment; selection of integral blowdown valves

Mounting: From horizontal to vertical (see Installation & Maintenance Instructions). Self-Draining and freeze-resistant when mounted in vertical position. Outlet plug location determines whether discharge is right-angled or straight-through

Line Sizes: 1/2", 3/4"

End Connections: NPT, BSPT, BSPP, SW, Raised Face Flanged (ANSI 105#, 300#, 600# or DIN)

**BENEFITS OF THE DELTA ELEMENT DESIGN**

The combination of thermostatic and thermodynamic forces make the Bestobell Delta Element steam traps more than a match for the steam curve. They are designed (and factory pre-set) to match virtually all of your applications and plant requirements - whether for tracing, dripleg, process, heating, or even high pressure service. Following the steam curve is the key to efficient steam trap performance as it provides you with the most energy efficient operation. The balanced pressure control operation of the Bestobell Delta Element trap matches the steam curve and allows efficient trap operation over wide pressure ranges.

**CAPACITY CHARTS: CONDENSATE CAPACITY AT DIFFERENTIAL PRESSURE**

Model DM25									
Size	Differential Pressure, psi (bar)	50 (3,4)	100 (6,9)	120 (8,3)	150 (10,3)	200 (13,8)	250 (17,2)	300 (20,7)	320 (22,1)
1/2"	Cold start-up, lbs/hr	1500	1950	2050	2200	2400	2600	2700	2800
	Hot (dripleg), lbs/hr	70	80	85	90	100	105	110	110
3/4"	Cold start-up, kgs/hr	680	885	930	998	1090	1180	1220	1270
	Hot (dripleg), kgs/hr	32	36	39	41	45	48	50	50

Note: Flow rates are based on discharge to atmospheric pressure, valid for back pressure up to 20% of inlet pressure. Higher back pressure requires reset of control element to obtain these capacities. Consult factory for details.

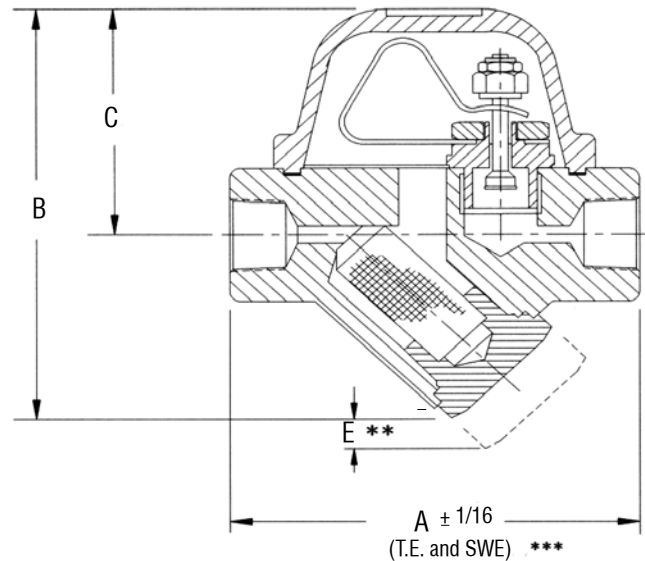
**MODEL DM25 SERIES DIMENSIONS**

Model DM25						
1/2"-3/4"	A	B	C	D	E	Wt
inches	4.00	5.00	3.25	3.125	2.25	5.5 lbs
mm	102	127	83	79	57	2,5 kg

Notes: dimension D is overall width; \*\* dimension E is withdrawal distance for strainer, \*\*\* dimensions shown are for threaded or socket weld ends, contact factory for other dimensions

