

Delta Element Steam Traps

DM40
DM64

DM100
DM160

DM320

CRN: Canadian Registration Number Available

FOR HIGH PRESSURE PROCESS SERVICES

An excellent choice for high pressure applications, these rugged steam traps provide fast start-up and high performance on steam main driplegs and pressure process applications with differential pressure ranges from 250 psi (17,2 bar) to 2000 psi (137,9 bar).

- **Single blade element** – offers long-term, trouble-free service because it's not prone to dirt build-up as encountered with many other bimetal designs
- **Stainless Steel internals** – leads to longer service life since materials are highly resistant to fatigue and corrosion
- **Easy maintenance** – traps are inline repairable when isolated from live steam system can be up and running again in minutes
- **Modulating discharge** – automatically adjusts to operating pressure and load, overcoming problems associated with cyclic discharge
- **Continuous air and CO2 venting** – maximizes heat transfer while minimizing corrosion

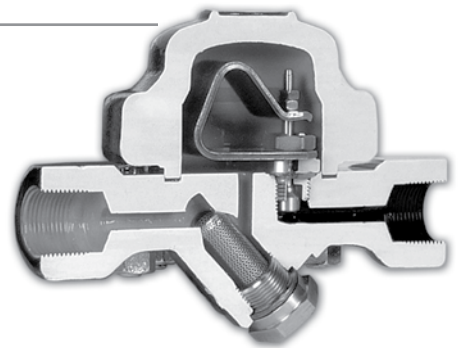

ORDERING SCHEMATIC

MODEL			6	7	8
D	M	0	4	0	2 1 0

MODEL			6	7	8
D	M	0	6	4	2 6 0

MODEL			6	7	8
D	M	1	0	0	2 7 0

MODEL			6	7	8
D	M	1	6	0	2 A 0

MODEL			6	7	8
D	M	3	2	0	2 A 0

6	SIZE
2	1/2" (All)
3	3/4" (All)
4	1" (All)

7	CONNECTIONS
1	NPT (All)
2	FSW (All)
5	600# Flange (All)
6	900# Flange (All but DM40)
7	1500# Flange (DM100, 160, 320)
A	2500# Flange (DM160 & DM320)
8	BSPT (All)
9	BSPP (All)
B	Buttweld (All)

8	SPECIALITIES
0	None
1	DTC
3	Integral Blowdown



BESTOBELLSTEAM
A Division of
Richards Industries
3170 Wasson Road
Cincinnati, OH 45209
toll free. 800.543.7311
local. 513.533.5600
fax. 513.871.0105
steam@richardsind.com
www.bestobellsteamtraps.com

FOR HIGH PRESSURE PROCESS SERVICES
SPECIFICATIONS

Line Sizes: 1/2", 3/4", 1"

End Connections:

All Sizes: NPT, BSPT, BSPP, SW, Raised Face Flanges ANSI 600#
 DM64 & DM100: Raised Face Flanges ANSI 900#
 DM100: Raised Face Flanges ANSI 1500#

MATERIALS

Body & Cover: Forged Carbon Steel A105 standard – DM100 available in F22 Chrome Moly (*designated by D100F model #*)

Valve Seat & Cone:

DM40, DM64 & DM100: 17/4 Stainless Steel / Special coating

Bi-Metal: NiCr / Invar

Strainer: 304 Stainless Steel

Nuts & Bolts:

DM40: Steel Gr BD
 DM64: Forged Steel B7
 DM100: Forged Steel B7

Gasket: Flexible Graphite

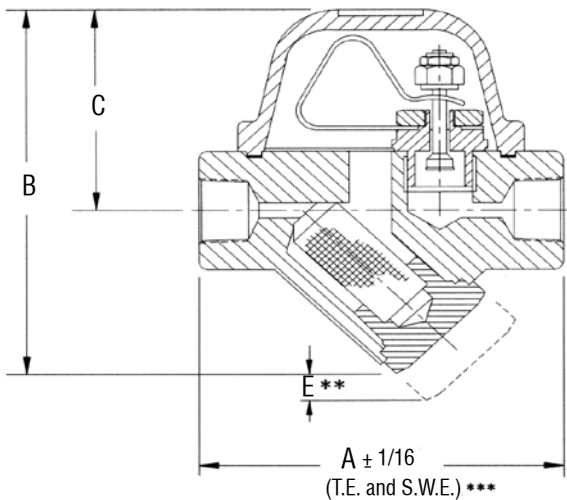
DIMENSIONS – DM40

Model DM40						
1/2"-3/4"	A	B	C	D	E	Wt
inches	4.00	6.00	3.625	4.00	2.625	8.4 lbs
mm	102	152	92	102	67	3.8 kgs
1"	A	B	C	D	E	Wt
inches	5.00	6.75	3.625	4.00	3.25	9.9 lbs
mm	127	171	92	102	83	4.5 kgs

SPECIFICATIONS

Maximum Differential Pressure:

Model DM40: 450 psi (31 bar)
 Model DM64: 600 psi (41 bar)
 Model DM100: 900 psi (62 bar)

Maximum Operating Pressure:

Model DM40: 750 psi (52 bar)
 Model DM64: 1500 psi (103 bar)
 Model DM100: 1500 psi (103 bar)

Maximum Body Temperature:

Model DM40: 750°F (399°C)
 Model DM64: 750°F (399°C)
 Model DM100: 750°F (399°C) Carbon Steel body
 Model D100F: 1000°F (538°C) F22 Chrome Moly body

Options: Double Threaded Strainer Cap (DTC) for blow-down, Double Threaded Strainer Cap (DTC) for blowdown valve attachment; selection of integral blowdown valves

Mounting: From horizontal to vertical (see Installation & Maintenance Instructions). Self-draining and freeze-resistant when mounted in vertical position.

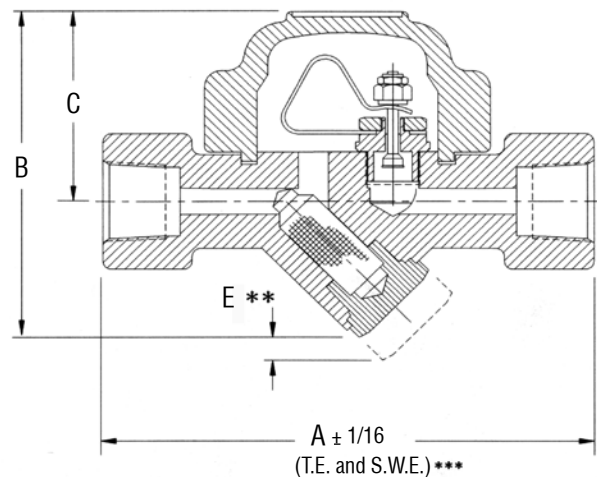
DIMENSIONS – DM64 & DM100

Model DM64 & DM100						
1/2"-3/4"	A	B	C	D	E	Wt
inches	4.00	6.00	3.625	4.00	2.625	8.4 lbs
mm	102	152	92	102	67	3.8 kgs
1"	A	B	C	D	E	Wt
inches	5.00	6.75	3.625	4.00	3.25	9.9 lbs
mm	127	171	92	102	83	4.5 kgs

Note: dimension D is overall width; ** dimension E is withdrawal distance for strainer

DM160 DM320 SERIES

DELTA ELEMENT STEAM TRAPS

FOR HIGHER PRESSURE PROCESS SERVICES

SPECIFICATIONS

Line Sizes: 1/2", 3/4", 1"

End Connections:

NPT, BSPT, BSPP, SW, BW, Raised Face Flanges ANSI 1500#, ANSI 2500 or DIN

MATERIALS

Body & Cover: Forged F22 Chrome Moly

Valve Seat & Cone: 17/4 Stainless Steel / Special coating

Bi-Metal: NiCr / Invar

Nuts & Bolts: Forged Steel B16

Gasket: Flexible Graphite

SPECIFICATIONS

Maximum Differential Pressure:

Model DM160: 1500 psi (103 bar)

Model DM320: 2000 psi (138 bar)

Maximum Operating Pressure:

Model DM160: 2400 psi (166 bar)

Model DM320: 2400 psi (166 bar)

Maximum Body Temperature:

Model DM160: 1000°F (538°C)

Model DM320: 1000°F (538°C)

Options: Double Threaded Strainer Cap (DTC) for blow-down, Double Threaded Strainer Cap (DTC) for blowdown valve attachment; selection of integral blowdown valves

Mounting: From horizontal to vertical (see Installation & Maintenance Instructions). Self-draining and freeze-resistant when mounted in vertical position.

DIMENSIONS – DM160 & DM320

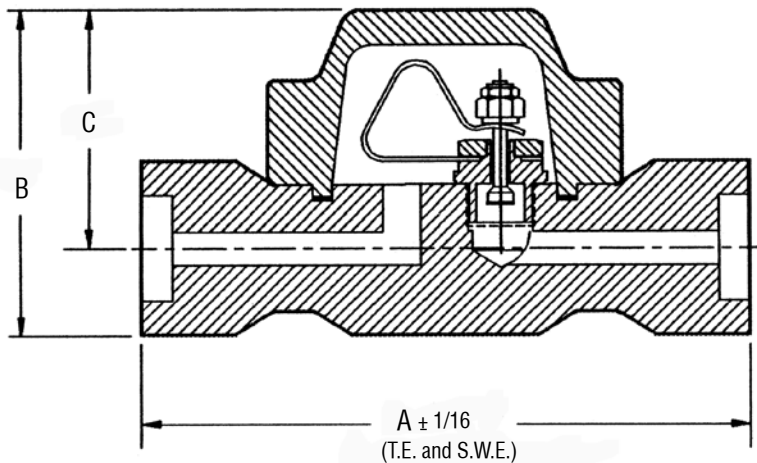

Model DM160 & DM320					
1/2", 3/4", 1"	A	B	C	D	Wt
inches	10.25	5.375	4.125	7.50	48 lbs
mm	280	137	105	191	22 kgs

Note: dimension D is overall width; dimensions shown are for threaded or socketweld ends. Contact factory for other dimensions.

FOR HIGH PRESSURE PROCESS SERVICES
**CAPACITY CHARTS: CONDENSATE CAPACITY
AT DIFFERENTIAL PRESSURE**

Model DM40		Consider M25 in this range				
Size	Differential Pressure, psi (bar)	250 (17,2)	300 (20,7)	350 (24,1)	400 (27,6)	450 (31,0)
1/2" & 3/4"	Cold start-up, lbs/hr	4500	5500	6500	7000	7500
	Hot (Dripleg), lbs/hr	500	700	750	850	950
	Cold start-up, Kg/hr	2041	2495	2948	3175	3402
	Hot (Dripleg), Kg/hr	227	318	340	386	431
1"	Cold start-up, lbs/hr	7500	9000	11000	12000	12500
	Hot (Dripleg), lbs/hr	800	1000	1200	1300	1300
	Cold start-up, Kg/hr	3402	4082	4990	5443	5670
	Hot (Dripleg), Kg/hr	363	454	544	590	590

Model DM64					
Size	Differential Pressure, psi (bar)	350 (24,12)	450 (31,0)	500 (34,5)	600 (41,4)
1/2", 3/4" & 1"	Cold start-up, lbs/hr	4000	5000	5250	5500
	Hot (Dripleg), lbs/hr	500	600	650	700
	Cold start-up, Kg/hr	1814	2268	2381	2495
	Hot (Dripleg), Kg/hr	227	272	295	316

Model DM100					
Size	Differential Pressure, psi (bar)	450 (31,0)	600 (41,4)	550 (51,7)	900 (62,0)
1/2", 3/4" & 1"	Cold start-up, lbs/hr	4500	5500	6100	6300
	Hot (Dripleg), lbs/hr	550	700	750	770
	Cold start-up, Kg/hr	2041	2495	2767	2858
	Hot (Dripleg), Kg/hr	250	318	340	340

Model DM160		Consider DM100 in this range			
Size	Differential Pressure, psi (bar)	900 (62,1)	1100 (75,9)	1300 (89,7)	1500 (103,5)
1/2", 3/4" & 1"	Cold start-up, lbs/hr	2000	3000	4000	4500
	Hot (Dripleg), lbs/hr	400	550	700	750
	Cold start-up, Kg/hr	907	1361	1814	2041
	Hot (Dripleg), Kg/hr	161	250	318	340

Model DM320		Consider DM160 in this range			
Size	Differential Pressure, psi (bar)	1200 (82,8)	1500 (103,5)	1750 (120,7)	2000 (137,9)
1/2", 3/4" & 1"	Cold start-up, lbs/hr	3500	4500	6000	7000
	Hot (Dripleg), lbs/hr	600	750	900	1000
	Cold start-up, Kg/hr	1588	2041	2722	3175
	Hot (Dripleg), Kg/hr	262	340	408	454