

Delta Element Steam Traps

Models
DM6
DM12

CRN: Canadian Registration Number Available

FOR STEAM MAIN DRIPLEG AND CRITICAL TRACING APPLICATIONS

A line of lightweight, yet rugged, steam traps that provide modulating discharge of light condensate loads without the loss of live steam. These fully maintainable steam traps feature energy-efficient operation with excellent start-up capacities for services with differential pressures up to 150 psi.

- **Maximum Differential Pressure** – DM6: 70 psi (4,8 bar); DM12: 150 psi (10,3 bar)
- **Easy maintenance** – traps are in-line repairable when isolated from live steam system and can be up and running again in minutes
- **Single blade element** – offers long-term, trouble-free service because it's not prone to dirt build-up as encountered with many other bimetal designs
- **Stainless Steel internals** – leads to longer service life since materials are highly resistant to fatigue and corrosion
- **Modulating discharge** – automatically adjusts to operating pressure and load, overcoming problems associated with cyclic discharge
- **Continuous air and CO2 venting** – maximizes heat transfer while minimizing corrosion

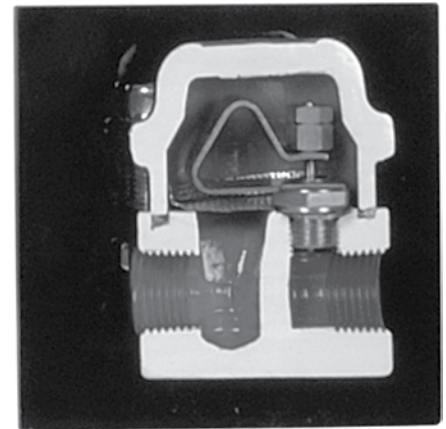

ORDERING SCHEMATIC

MODEL							
D	M	0	0	6	1	1	0

MODEL							
D	M	0	1	2	1	1	0

6	SIZE
1	3/8"
2	1/2"
3	3/4"

7	CONNECTIONS
1	NPT (All)
2	FSW (All)
8	BSPT (All)
9	BSPP (All)

8	SPECIALITIES
0	None



BESTOBELLSTEAM
 A Division of
 Richards Industries
 3170 Wasson Road
 Cincinnati, OH 45209

toll free. 800.543.7311
 local. 513.533.5600
 fax. 513.871.0105

steam@richardsind.com
 www.bestobellsteamtraps.com

FOR STEAM MAIN DRIPLEG AND CRITICAL TRACING APPLICATIONS

SPECIFICATIONS

Maximum Differential Pressure:

Model DM6: 70 PSI (4,4 bar)

Model DM12: 150 psi (10,3 bar)

Maximum Operating Pressure: 750 PSIG (52 bar)

Maximum Body Temperature: 750°F (399°C)

MATERIALS

Body & Cover: Forged Carbon Steel A105

Valve Seat: 303 SST

Cone: 17-4 SST

Bi-Metal: Stainless Steel NiCr

Strainer: Stainless Steel 304

Bolts: Steel Gr8

Gasket: Flexible Graphite

End Connections: NPT, BSPT, BSPP, SW

Mounting: From horizontal to vertical (see Installation & Maintenance Instructions). Self-Draining and freeze-resistant when mounted in vertical position.

Line Sizes: 3/8", 1/2", 3/4"

MODEL DM6 & DM12 SERIES DIMENSIONS

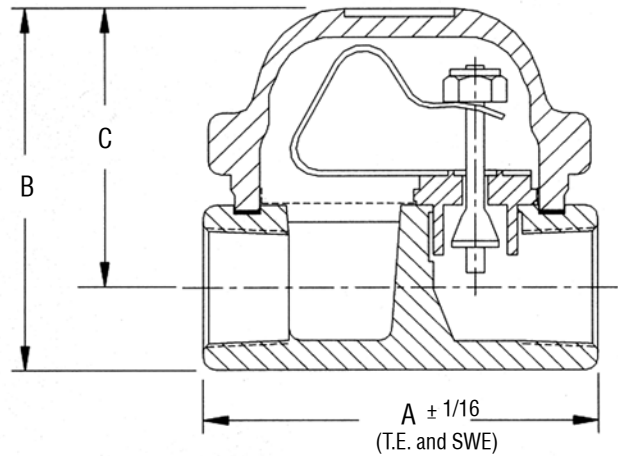

Model DM6 & DM12					
3/8", 1/2"	A	B	C	D	Wt
inches	2.438	3.0	2.25	2.438	2.2 lbs
mm	62	76	57	62	1,0 kg
3/4"	A	B	C	D	Wt
inches	4.563	3.125	2.25	2.438	3.0 lbs
mm	116	80	57	62	1,4 kg

Notes: dimension D is overall width; **dimensions shown are for threaded or socket weld ends, contact factory for other dimensions

CAPACITY CHARTS: CONDENSATE CAPACITY AT DIFFERENTIAL PRESSURE

Model DM6		For larger capacities consider Model GM3								
Size	Differential Pressure, psi (bar)	2 (0,14)	5 (0,34)	10 (0,70)	20 (1,4)	30 (2,1)	40 (2,8)	50 (3,5)	60 (4,1)	70 (4,8)
3/8"	Cold start-up, lbs/hr	500	700	1000	1700	2000	2300	2400	2600	2700
	Hot (dripleg), lbs/hr	30	65	90	110	130	140	150	150	150
1/2"	Cold start-up, kgs/hr	227	317	454	771	907	1043	1089	1179	1225
	Hot (dripleg), kgs/hr	12	29	40	49	58	63	68	68	68
Model DM12		For larger capacities consider Model DM6								
Size	Differential Pressure, psi (bar)	10 (0,69)	20 (1,4)	30 (2,1)	50 (3,5)	70 (4,8)	90 (6,2)	110 (7,6)	130 (8,9)	150 (10)
3/8"	Cold start-up, lbs/hr	750	1200	2200	2900	3500	4000	4200	4300	4500
	Hot (dripleg), lbs/hr	60	70	80	90	100	105	110	110	115
1/2"	Cold start-up, kgs/hr	340	544	998	1315	1588	1814	1905	1950	2041
	Hot (dripleg), kgs/hr	27	31	36	49	45	47	49	49	52

Note: Flow rates are based on discharge to atmospheric pressure, valid for back pressure up to 20% of inlet pressure. Higher back pressure requires reset of control element to obtain these capacities. Consult factory for details.