

Thermodynamic Disc Traps

Models
DT711
DT71S

THERMODYNAMIC DISC TRAPS

The DT711 Series is a line of compact, lightweight, thermodynamic style disc traps designed to efficiently discharge condensate on applications with working pressures up to 711 psi. Available with or without an integral strainer.

- Single moving part
- Wide pressure range
- Rugged design
- Designed to fail open
- Unaffected by freezing
- Easy to check cyclic operation
- Unaffected by water hammer
- Designed for superheat
- NPT ends standard, BSP ends available



ORDERING SCHEMATIC

MODEL		5	6	7	8
D	T	7	1	1	0

MODEL		5	6	7	8
D	T	7	1	S	0

5	BODY TYPE
1	Standard
S	with Integral Strainer

6	SIZE
1	3/8"
2	1/2"
3	3/4"
4	1"

7	CONNECTIONS
1	NPT (All)
8	BSPT
9	BSPP

8	SPECIALS
0	None



BESTOBELLSTEAM

A Division of
 Richards Industries
 3170 Wasson Road
 Cincinnati, OH 45209

toll free. 800.543.7311
 local. 513.533.5600
 fax. 513.871.0105

steam@richardsind.com
 www.bestobellsteamtraps.com

THERMODYNAMIC DISC TRAPS
SPECIFICATIONS

Maximum Pressure Allowable: 711 PSI (49 bar)

Maximum Operating Back Pressure: at the outlet should not exceed 70% of the inlet pressure

Minimum Differential Pressure for Satisfactory Operation: 3.5 psi (0,24 bar)

Maximum Temperature Allowable: 799°F (426°C)

MATERIALS

Body: ASTM A743 Gr. CA 40

Disc Cap: ASTM A743 Gr. CA 40

Strainer Cap: ASTM A743 Gr. CA 40

Screen: AISI 304

Disc: AISI 410

APPLICABLE CODES & STANDARDS

End connections per ANSI B1.20.1 for threaded

SAMPLE SPECIFICATION

Steam traps shall be all stainless steel disc type with connections on a common center line, which will operate in any position, Integral seat design with hardened disc and seating surfaces.

RECOMMENDED INSTALLATION

From equipment being drained

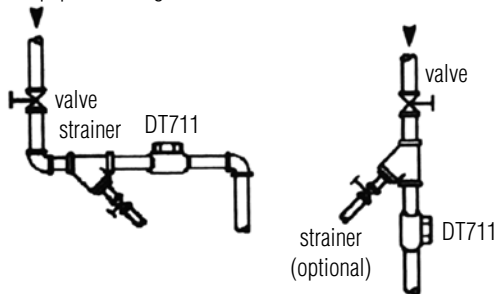

CAPACITY CHART

Size	Differential Pressure, PSI																	
	5	10	20	30	50	75	100	150	200	250	300	350	400	450	500	550	600	711
3/8"	392 (178)	408 (185)	439 (200)	469 (213)	529 (240)	603 (274)	675 (307)	813 (370)	944 (429)	1069 (486)	1186 (539)	1297 (589)	1400 (636)	1496 (680)	1586 (721)	1668 (758)	1744 (793)	1886 (857)
1/2"	392 (178)	408 (185)	439 (200)	469 (213)	529 (240)	603 (274)	675 (307)	813 (370)	944 (429)	1069 (486)	1186 (539)	1297 (589)	1400 (636)	1496 (680)	1586 (721)	1668 (758)	1744 (793)	1886 (857)
3/4"	392 (178)	408 (185)	439 (200)	469 (213)	529 (240)	603 (274)	675 (307)	813 (370)	944 (429)	1069 (486)	1186 (539)	1297 (589)	1400 (636)	1496 (680)	1586 (721)	1668 (758)	1744 (793)	1886 (857)
1"	716 (325)	739 (336)	783 (356)	826 (380)	912 (415)	1015 (461)	1111 (505)	1304 (593)	1478 (672)	1638 (744)	1783 (810)	1914 (870)	2030 (923)	2132 (969)	2219 (1009)	2292 (1042)	2350 (1068)	2427 (1103)

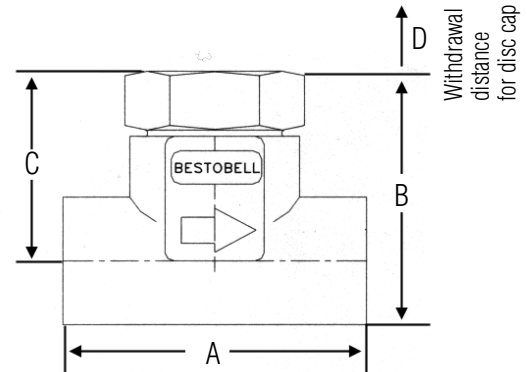
Capacities represent condensate in lbs/hr; kg/hr shown in (). 1 psi = 0.0689 bar

DIMENSIONS

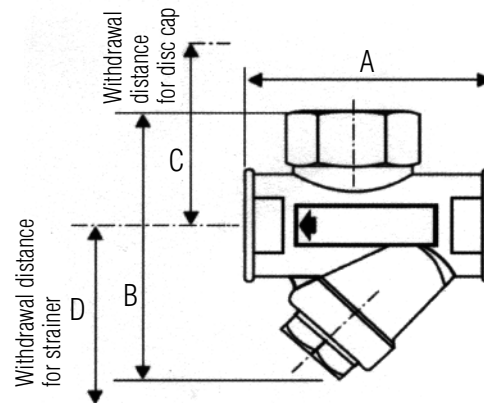
Size	A	B	C	D	Wt lb (kg)
3/8"	2.36 (60)	2.44 (62)	1.69 (43)	1.57 (40)	1.4 (0,7)
1/2"	2.56 (65)	2.44 (62)	1.69 (43)	1.57 (40)	1.7 (0,8)
3/4"	2.56 (65)	2.56 (65)	1.69 (43)	1.57 (40)	1.7 (0,8)
1"	3.35 (85)	2.87 (73)	1.97 (50)	1.77 (45)	3.5 (1,6)



Size	A	B	C	D	Wt lb (kg)
3/8"	3.15 (80)	4.02 (102)	3.19 (81)	3.54 (90)	2.2 (1,0)
1/2"	3.15 (80)	4.02 (102)	3.19 (81)	3.54 (90)	2.2 (1,0)
3/4"	3.15 (80)	4.02 (102)	3.19 (81)	3.54 (90)	2.2 (1,0)
1"	3.78 (96)	4.76 (121)	3.58 (91)	4.25 (108)	4.8 (2,2)