

Delta Element Steam Traps

Models
M16
GM16

CRN: Canadian Registration Number Available

FOR PROCESS AND HEATING SYSTEMS

A series of steam traps designed to handle the varying loads on process applications and provide fast start-up and modulating service with no live steam loss.

- **Maximum operating differential pressure:** 200 psig / 13,8 bar
- **Single blade element** – offers long-term, trouble-free service because it's not prone to dirt build-up as encountered with many other bimetal designs
- **Stainless Steel internals** – leads to longer service life since materials are highly resistant to fatigue and corrosion
- **Modulating discharge** – automatically adjusts to operating pressure and load, overcoming problems associated with cyclic discharge
- **Integral strainer and check valve** – strainer protects trap from dirt while check valve prevents backflow during shutdown
- **Continuous air and CO2 venting** – maximizes heat transfer while minimizing corrosion
- **Easy maintenance** – traps are in-line repairable when isolated from live steam system and can be up and running again in minutes

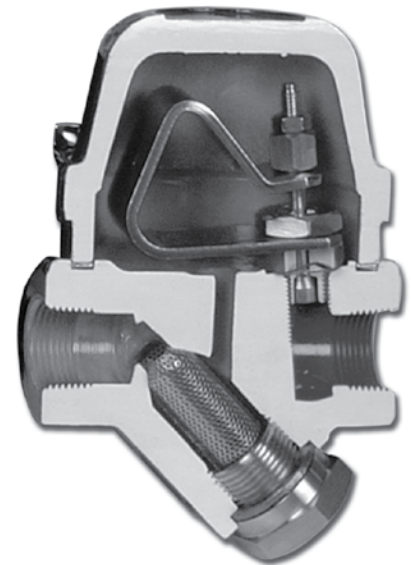

ORDERING SCHEMATIC

MODEL							
M	0	0	1	6	6	1	0

MODEL							
G	M	0	1	6	2	1	0

6	SIZE
2	1/2" (All)
3	3/4" (All)
4	1" (M16)
6	1-1/2" (M16)
7	2" (M16)

7	CONNECTIONS
1	NPT
2	FSW
3	150# Flange
4	300# Flange
5	600# Flange
8	BSPT
9	BSPP

8	SPECIALITIES
0	None
1	DTC
3	Integral Blowdown



BESTOBELLSTEAM
A Division of
Richards Industries
3170 Wasson Road
Cincinnati, OH 45209

toll free. 800.543.7311
local. 513.533.5600
fax. 513.871.0105

steam@richardsind.com
www.bestobellsteamtraps.com

FOR PROCESS AND HEATING SYSTEMS
SPECIFICATIONS

Maximum Differential Pressure: 200 PSIG (13,8 bar)

Maximum Operating Pressure: 750 PSIG (52 bar)

Maximum Body Temperature: 750°F (399°C)

MATERIALS

Body & Cover: Forged Carbon Steel A105

Valve Seat 303 SST & Cone: 17-4 SST

Bi-Metal: Stainless Steel NiCr

Strainer: Stainless Steel 304

Bolts: Steel Gr8

Gasket: Flexible Graphite

Options: Double Threaded Strainer Cap (DTC) for blowdown valve attachment; selection of integral blowdown valves

Mounting: From horizontal to vertical (see Installation & Maintenance Instructions). Self-Draining and freeze-resistant when mounted in vertical position.

Line Sizes:

Model M16: 1/2", 3/4", 1", 1-1/2", 2"

Model GM16: 1/2", 3/4"

End Connections: Threaded NPT, BSPT, BSPP, SW, Raised Face Flanges (ANSI 150, 300, 600, DIN)

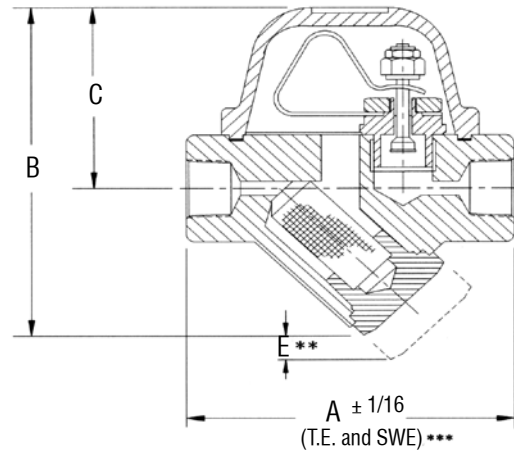

Model M16						
1/2"-3/4"	A	B	C	D	E	Wt
inches	4	6	3.625	4	2.625	8.4 lbs
mm	102	152	92	102	67	3.8 kg
1"	A	B	C	D	E	Wt
inches	5	6.75	3.625	4	3.5	9.9 lbs
mm	127	171	92	102	89	4.5 kg
1-1/2", 2"	A	B	C	D	E	Wt
inches	7.125	9.5	6	4	2.625	33 lbs
mm	181	241	152	102	67	15 kg
Model GM16						
1/2"-3/4"	A	B	C	D	E	Wt
inches	4	6	3.625	4	2.625	8.4 lbs
mm	102	152	92	102	67	3.8 kgs

Notes: dimension D is overall width; ** dimension E is withdrawal distance for strainer, *** dimensions shown are for threaded or socket weld ends, contact factory for other dimensions

CAPACITY CHARTS: CONDENSATE CAPACITY AT DIFFERENTIAL PRESSURE

Model M16		Consider "10" Series traps in this range			
Size	Differential Pressure, psi (bar)	50 (3,45)	100 (6,9)	150 (10,3)	200 (13,8)
1/2"	Cold start-up, lbs/hr	3600	5000	6000	6300
	Hot (Dripleg), lbs/hr	150	180	200	200
3/4"	Cold start-up, Kg/hr	1632	2268	2721	2857
	Hot (Dripleg), Kg/hr	68,0	81,6	90,7	90,7
1"	Cold start-up, lbs/hr	6000	8000	9000	10000
	Hot (Dripleg), lbs/hr	1200	1500	1700	1800
	Cold start-up, Kg/hr	2721	3628	4082	4536
	Hot (Dripleg), Kg/hr	544	680	771	816
1-1/2" & 2"	Cold start-up, lbs/hr	12000	18000	23000	30000
	Hot (Dripleg), lbs/hr	1700	2200	2800	3300
	Cold start-up, Kg/hr	5443	8164	10432	13608
	Hot (Dripleg), Kg/hr	771	997	1270	1496
Model GM16		Consider "GM10" Series traps in this range			
Size	Differential Pressure, psi (bar)	50 (3,5)	100 (6,9)	150 (10,3)	200 (13,8)
1/2"	Cold start-up, lbs/hr	6000	8000	9000	10000
	Hot (Dripleg), lbs/hr	700	950	1200	1400
3/4"	Cold start-up, Kg/hr	2721	3628	4982	4536
	Hot (Dripleg), Kg/hr	317	430	544	635

Note: Flow rates are based on discharge to atmospheric pressure, valid for back pressure up to 20% of inlet pressure. Higher back pressure requires reset of control element to obtain these capacities. Consult factory for details.