



BESTOBELLSTEAM

3170 Wasson Road • Cincinnati, OH 45209 USA
Phone 513-533-5600 • Fax 513-871-0105
steam@richardsind.com • www.bestobellsteamtraps.com

Universal Traps

Installation & Maintenance Instructions for Bestobell Steam Universal Traps

Warning: Bestobell Steam products must only be used, installed and repaired in accordance with these Installation & Maintenance Instructions. Observe all applicable public and company codes and regulations. In the event of leakage or other malfunction, call a qualified service person; continued operation may cause system failure or a general hazard. Prior to servicing equipment, disconnect, shut off, drain and/or bypass all pressurized fluids.

Pre-Installation

1. Blow out piping to remove any scale or dirt.
2. Verify that your Bestobell steam trap will meet system conditions by checking the nameplate for operating differential pressure and maximum pressure and temperature limits of the trap body.
3. The pipe connector (25) can be oriented in many positions as long as the trap mounting surface is either horizontal or vertical when the trap body is mounted. See orientation as shown below.
4. The flow arrow in the pipe connector must be in the direction of the flow, otherwise the trap will not operate because the integral check valve will not allow flow in reverse direction

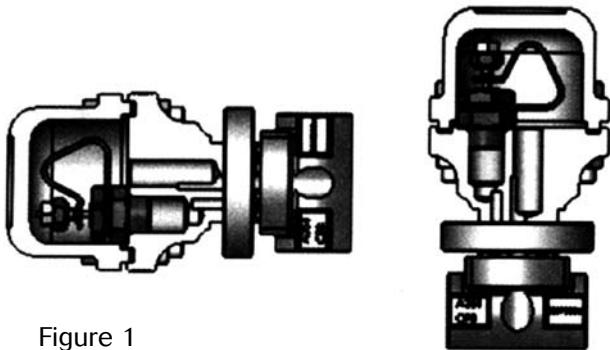
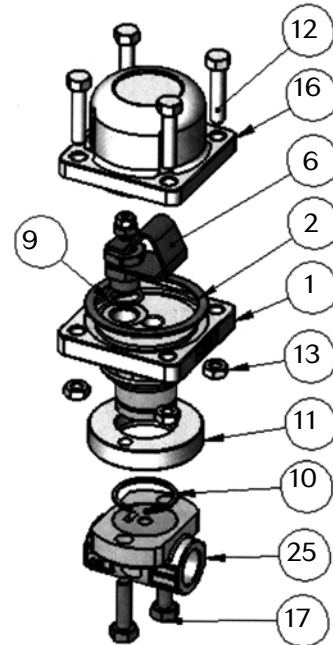

Figure 1

2. The trap should be orientated as shown in Figure 1 by rotating the swivel flange (11) to align with the bolts in the connector. For horizontal trap mounting, the word "TOP" on the body casting (1) should be facing up.
3. Secure the two bolts initially by hand and then tightening to 24 ft-lbs using a 9/16" wrench.
4. Be sure to check that both inner and outer gaskets are in position before making connection.
5. Pipe connections can be purchased with strainer and an optional integral blowdown valve.



Installation

1. Once the pipe connector has been installed, the steam trap can be mounted to it using the two bolts (17) with a suitable anti-seize compound applied to them.

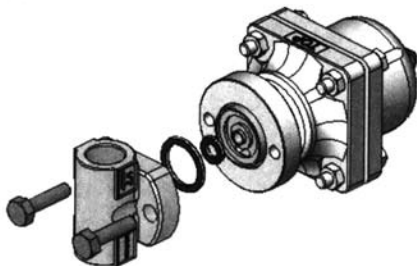

Item	Part Name	Material	Qty
1	Body	CF8 SST	1
2	Body Gasket	Grafoil	1
6	Control Element	SST	1
9	C/E Gasket	Grafoil	1
10	Snap Ring	303 SST	1
11	Swivel Flange	304SST	1
12	Cover Bolts	GR8	4
13	Cover Nuts	GR8	4
16	Cover	CF8 SST	1
17	Connector Bolts	GR8	2
25	Connector	CF8 SST	1

Maintenance

The Universal Steam Trap can be readily overhauled by replacing the Delta control element as a **complete assembly**. A new factory replacement control element and gasket should always be used as this will be correctly calibrated to restore your trap to its original efficiency.

The complete assembly including pipe connector must be isolated from the steam supply before removal or opening of the delta steam trap.

To repair the trap by replacing the control element:

1. Before removing the cover (16), the trap must be isolated from live steam lines and condensate return lines, and internal pressure in the trap should be relieved via venting to atmosphere or by cooking the trap to ambient temperature.
2. Loosen and remove the cover bolts (12) and cover (16).
3. Loosening the bimetal locknut enables insertion of an open-end wrench under the bimetal (6) to free the valve seat. Unscrew the valve seat from the body.
4. Before installing the new element/valve assembly (6), clean the valve seating face on the body with a wire brush. Inspect to ensure that all gasket seating surfaces are undamaged.
5. The replacement element assembly is factory preset. It is vital that, during installation, the adjusting nut and locknut on the spindle are not disturbed.
6. Unscrew the bimetal locknut to allow a wrench to be placed between the bimetal and body for tightening of the seat into the body. Install the gasket (9) on the base, and screw the valve seat into the body and tighten to 20 ft-lbs using 7/8" wrench.
7. Line up the bimetal with the inlet and outlet ports to ensure clearance once the cover is replaced, then tighten the bimetal locknut.
8. Before replacing the cover, clean the cover gasket faces thoroughly and insert replacement cover gasket (2).
9. Replace the cover and bolts (12) with the bolt heads on the cover side and hand-tighten the nuts. Torque the cover bolts in two stages: initially to 50% and finally to the full 15 ft-lbs. At each stage tighten in a diagonal cross pattern.

To replace the Universal Trap mounted to the pipe connector:

1. Remove the universal trap assembly by unbolting the two connecting bolts (17).
2. Clean the face of the connector with a soft scraper before attaching a replacement trap.

3. It is recommended that new replacement inner and outer spiral wound gaskets be used whenever maintenance is done.
4. A suitable anti-seize compound should be applied to the screw threads before tightening to 24 ft-lbs.

To clean or replace the strainer:

1. Remove strainer cap (4) using a 1-1/4 wrench and replace or clean strainer (2).
2. Clean the gasket faces and insert strainer (2) tapered end first.
3. Replace the gasket (3) and tighten strainer cap (4) to 50 ft-lbs torque.

To repair the blowdown valve, see Integral Blowdown Valve I & M.

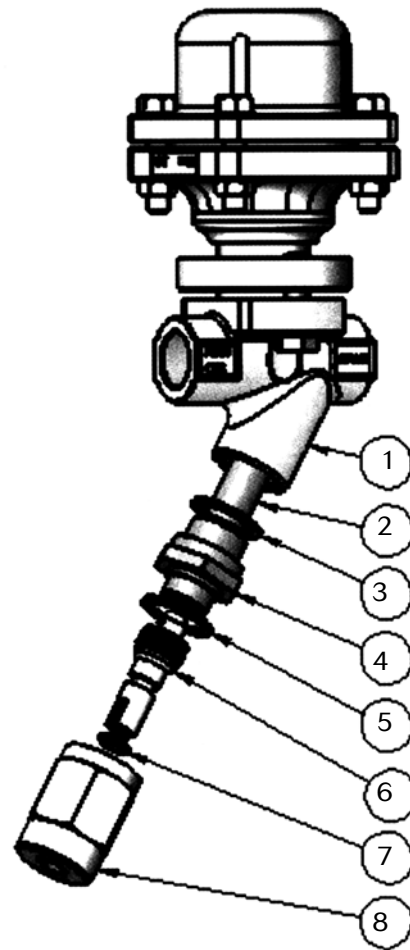

Item	Part Name	Material	Qty
1	Connector	CF8 SST	1
2	Strainer	304 SST	1
3	Gasket	Grafoil	1
4	Strainer Cap	303 SST	1
5	Gasket	Grafoil	1
6	Stem	17-4 SST	1
7	O-Ring	EPDM	1
8	Bonnet	303 SST	1